

Kocioł parowy trójciągowy
Steam generator

Disegno / Drawing Nr. 3936955/0
rev. 07-03-2012

Maks. ciśnienie robocze
Ciśnienie testowe
Temperatura projektowa

Max working pressure 12 bar
Hydraulic test pressure 21 bar
Design temperature 191,7 °C

Projekt zgodnie z normą EN 12953
Design conform to EN 12953

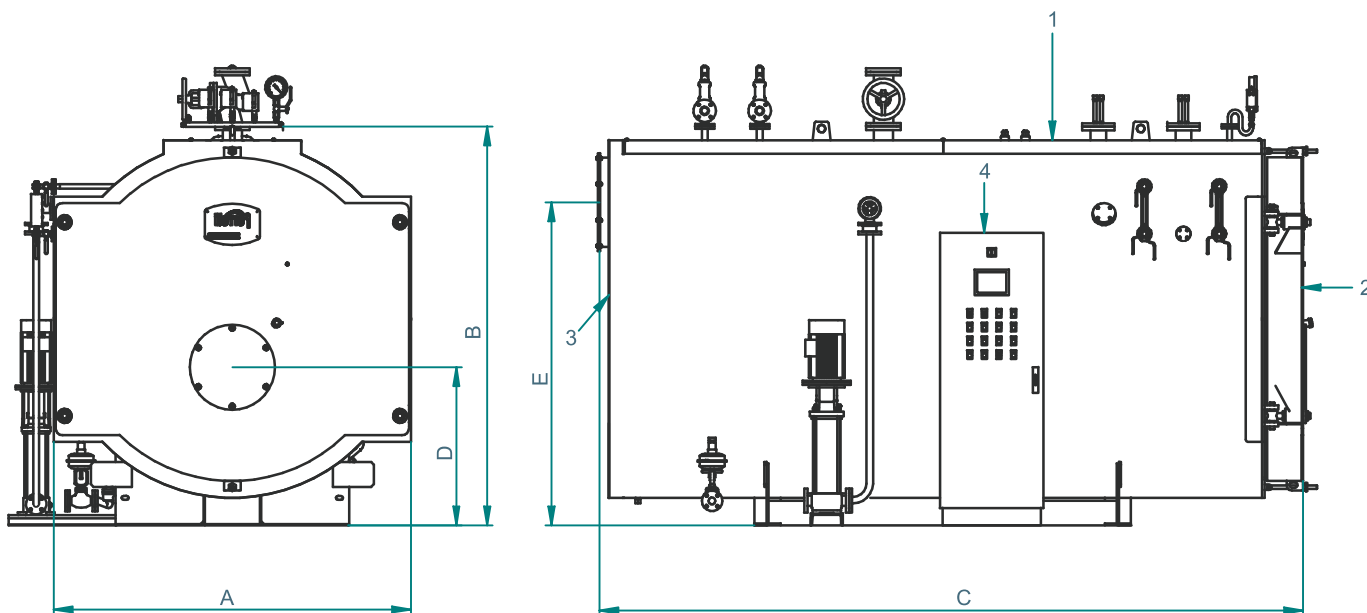

Legenda

- 1 Kocioł
- 2 Komora spalin - przednia
- 3 Komora spalin - tylna
- 4 Szafa sterownicza

Key

- 1 Boiler
- 2 Door
- 3 Smokebox
- 4 Electrical panel

VAPOPREX 3G N		1000	1250	1500	1750	2000	2500	3000	3500	4000	4500
Moc cieplna - Heat output	KW	1109	1453	1744	2035	2326	2907	3483	4070	4651	5233
Obciążenie cieplne - Heat input	KW	1232	1615	1938	2261	2584	3230	3876	4522	5168	5814
Produkcja pary - Steam production Atm. 80°	t/h	1,691	2,140	2,580	2,935	3,412	4,310	5,170	5,970	6,840	7,676
Opór po stronie spalin* - Press. drop flue gas side*	mbar	4	4,6	5,7	6,8	5	6	7,5	6	8,5	9
Ciężar kotła na sucho - Dry weight	kg	6300	8950	8800	9450	11250	13250	14250	15750	17200	18200
WYMIARY - DIMENSIONS	A mm	2000	2000	2200	2200	2200	2300	2300	2500	2500	2500
	B mm	2300	2300	2500	2500	2500	2700	2700	2900	2900	2900
	C mm	3635	3935	4235	4635	4885	4935	5385	5235	5535	6185
	D mm	858	858	908	908	908	1044	1044	1085	1085	1085
	E mm	1750	1750	1900	1900	1900	2100	2100	2275	2275	2275

* Paliwo - olej: CO₂ = 13% - Paliwo - gaz: CO₂ = 10% / Oil fuel: CO₂ = 13% - Gas fuel: CO₂ = 10%