

Maksymalne ciśnienie robocze\* / Max working pressure\* 4,9 / 12 bar  
Ciśnienie testowe / Hydraulic test pressure 8,57 / 21 bar  
Temp. projektowa / Design temperature 158 / 191,7°C

\*Na zamówienie dostępna wersja o maksymalnym ciśnieniu roboczym 14,8 bar / \*Max working pressure on request 14,8 bar

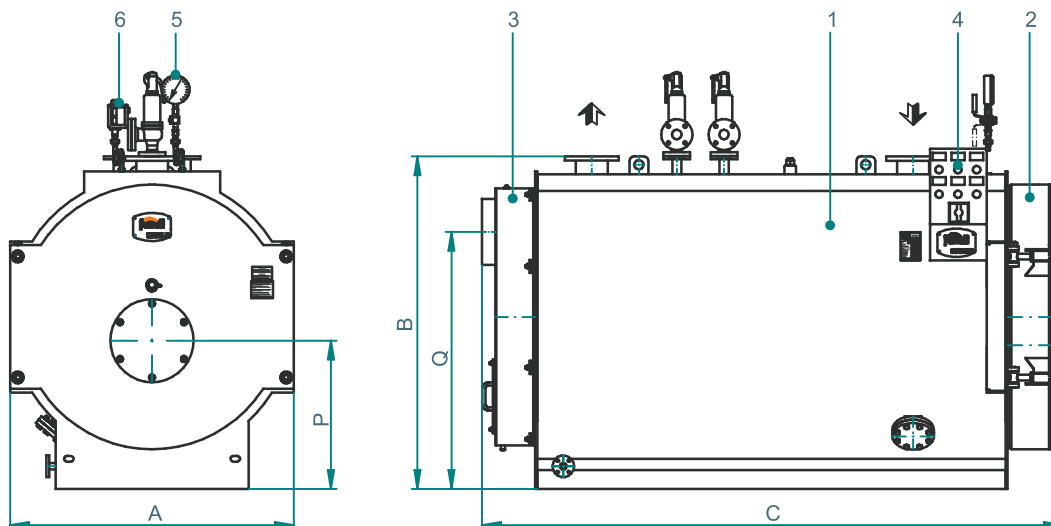

Legenda:

1. Kocioł
2. Drzwi
3. Komora spalin
4. Tablica sterownicza
5. Manometr
6. Presostat

Key:

1. Boiler
2. Door
3. Smokebox
4. Electrical Panel
5. Pressure Gauge
6. Pressure Switches

PREX N ASL / ASH	4,9 / 12 bar	Typ	160	280	410	560	700	1000	1210	1400	1740	2080	2350	2800	3500
Moc cieplna / Heat output		kW	150	280	410	560	700	1000	1210	1400	1740	2080	2350	2800	3500
Obciążenie cieplne / Heat input		kW	178	311	456	622	778	1111	1344	1550	1933	2311	2611	3111	3889
Opory w komorze spalania / Furnace backpressure		mbar	2,7	3,5	4,5	5,0	6,0	6,8	7,0	7,0	8,0	8,3	9,0	10,0	10,5
Wymiary / Dimensions	A	mm	900	960	1060	1190	1310	1310	1310	1500	1620	1750	1860	1860	1960
	B	mm	1130	1190	1290	1420	1420	1570	1570	1760	1910	2060	2170	2170	2310
	C	mm	1740	2000	2190	2350	2540	2820	3040	3070	3320	3360	3620	3920	4830
	P	mm	580	610	660	630	630	725	725	785	860	935	990	990	1080
	Q	mm	840	890	935	1070	1070	1200	1200	1360	1510	1630	1750	1750	1820
Ciężar / Weight	ASL	kg	680	770	1000	1260	1390	1870	2000	2490	3360	3800	4720	5120	6100
Ciężar / Weight	ASH	kg	820	920	1200	1540	1690	2300	2660	3150	4200	4750	5900	6400	7800